

EXPORT

 English Version

Herkules
TECHNIK  FÜR MENSCHEN

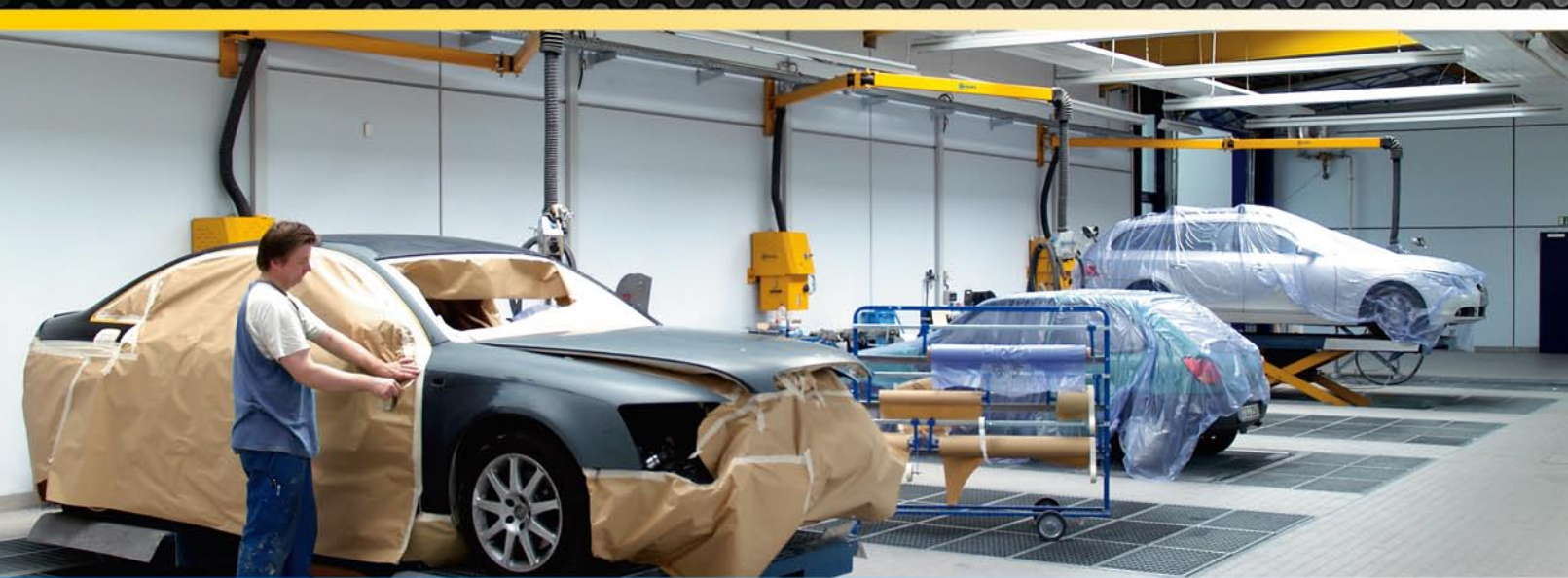

General Catalogue
V 10

Herkules

TECHNIK  FÜR MENSCHEN



Herkules has designed and manufactured "technique for people" since 1974. In close co-operation with users "on site", we create workshop equipment which is economically smart with and through its ergonomics.

Superior technique setting standards: Lifts for paint- and bodyshops, automatic spray gun cleaners, dust extraction units.

These are all examples for products which have become state of art for modern, future orientated workshops.

The Herkules concept "technique for people" has been successfully incorporated.

The products are worldwide highly acknowledged and distributed.

A selection of people and brands relying on us:

Akzo Coatings · Audi · BMW
Deutsche Bahn AG · Ford · Glasurit
Nexa Autocolor · Lufthansa
Volkswagen · Opel · Daimler AG
DuPont · Porsche · Standox
Spies Hecker



By means of the newest tools and machines, Herkules produces and manufactures high quality paint- and bodyshop products at our headquarters in Kassel. Thanks to numerous user experiences, innovative technology and well-planned concepts, Herkules is able to make the products suit the high demands on the market.

The quality of our products - expressed through a 3 year guarantee on all lifts - is ensured during the entire production in Kassel. The lifts and the spray gun cleaners are all 100 % made in Germany.

We would like to invite you to our exhibition and training centre in Kassel, where you can see and test all of our products.

Welcome!



Herkules is delighted to present some new products to you in this catalogue. They are all of the finest Herkules-quality, and loyal to our concept "technique for people" - this is not only our corporate philosophy, but also a promise to our customers.

Products:



Lifts I

Lift HLS-1600 The professional lift with a working height of 1600 mm	6
Lift HLS-1200 For paint- and bodyshops	8
Lift HLS 1200 Duo Two Lift systems perfekt combined	NEW! 10
Lift HLS 1600 Duo With even more performance	NEW! 11
Lift HLQ For spraybooths with sideways transportation on roller trolley	12
Lift HLS 1600 U Comfortable work on the top of the car	13
Painter-Lift The working lift for the painter	14
Transmobil The workshop transportation system	16

Lifts II

Herkules-lift mobil The lift for the bodyshop	18
Herkules-lift RS Tyre service lift	20
Lift K 700 Maintenance lift for the workshop	21

Cleaning

Cleanpoint The spray gun cleaning system	22
Herkules-lift Duplo/Duplo Aqua Double cleaning stations	24
Herkules Aqua-Rinse Spray gun cleaner	25



Hexadust Central dust extraction system

26

Hexacomb Turbo Dust extraction for self-installation

28

T-2 mobile

30

Hoses

31

Dust Extraction

Lucky table

32

Paint stand

32

Drain station

33

Paper baler

34

Step-bench

34

Herkules - your contact

35

Workshop

Herkules HLS 1600

The paint- and bodyshop lift with increased lifting height



Modified dimensions for better work with Vans, SUVs and 4x4's.

The intelligent construction with the innovative extras and the extended lifting height makes the HLS-1600 the perfect professional lift for the future-oriented paintshops. Thanks to its compact construction, the lift is also suited for smaller workshops. Due to its fold down driving tracks and a drive-on ramp which is level with the rest of the lift, working with the HLS-1600 is easier than working with many other lift types.



The new HLS-1600 has both: a new compact construction method and an extended lifting height which is superior to traditional lifts.



on-ground

Ready for immediate use. Easy accessible due to the ramps.

Item No.: HLS1600-11



flush mounted

Flush mounted to concrete or grids. Ideal for new installation sites.

Item No.: HLS1600-14



Working height	ca. 1600 mm
Lifting height	1300 mm
Loading capacity	3.0 to
Weight	800 kg
Air supply	8 bar

Installation dimensions on request.

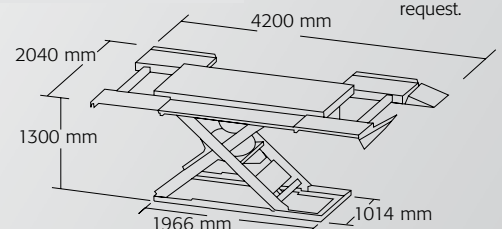



HLS 1600 in use



Smooth lifting and lowering to desired working height



The driving tracks (which can be used to put tools on) will be lifted simultaneously with the rest of the lift. They can be folded down if necessary, for example for works on the car sills and the lower parts of the vehicle.



flush mounted



Drive on ramps turn away and thus do not overlap and facilitate access to the vehicle

Herkules HLS 1200

The perfect lift for preparation and finish

The perfect lift for paint and body-shops.
Facilitates work and improves quality.

Nearly 85 % of all car damages require the worker to work in a stooped position. This causes fatigue and can also lead to long-term health problems. With the special paint-lift, the work can be done in an ergonomically correct upright position. The work efficiency is increased and the quality is improved by better visual control opportunities.



on-ground

Simply fix with screws and dowels, and the lift is ready for immediate use. It has a drive-over height of only 100 mm. Working height ~ 1100 mm

Item No.: HLS1200-11



flush mounted

Flush mounted to concrete or grids. Ideal for new sites. Working height ~ 1000 mm Recessed depth 115 mm

Item No.: HLS1200-14

rail transport

Lift for rail transport Working height ~ 1100 mm

Item No.: HLS1200-13



Loading capacity	2.5	to
Weight	700	kg
Air supply	8	bar

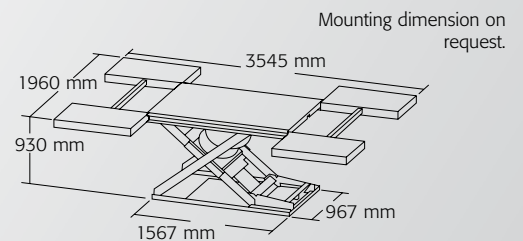



HLS 1200 in use



Smooth lifting and lowering to desired working height for optimal approach to damaged area.



The easy installation facilitates an individual planning of body shops by using the existing space optimally.



Quality is increased by ergonomic work in an uncramped posture.

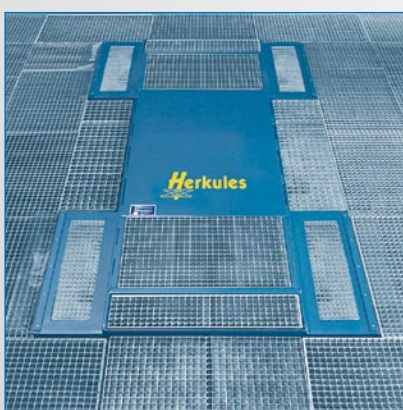

flush mounted



The lift HLS as in-ground installation in the spray booth.

HLS 1200 Duo

Two Lift systems perfect combined

The workshop lifts for all standards. The lifting of the car could be either on wheels or for wheel free work.

Uncramped posture and better visibility improve quality thanks to different working heights that can be changed smoothly.

Due to its fold down driving tracks and ramps which is level with the rest of the lift, working is easier.



Easy positioning of the liftings points also of extremely flat vehicles.



on-ground

Installation height only 110 mm
working height: ~ 1100 mm

Item No.: HLS1200-Duo-11



flush mounted

Optimal flush mounted installation. It is particularly advantageous for new buildings.

Working height ~ 1000 mm
Installation depth 115 mm

Item No. HLS1200-DUO-14

Loading capacity	2.5	to
Length of the platform	3545	mm
Width of the platform	1900	mm
Weight	850	kg
Air supply	8	bar



Alternatively



NEW!

Now available in flush mounted version

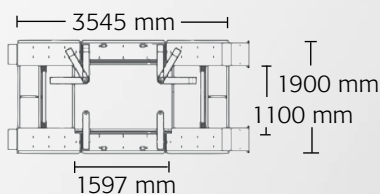

HLS 1600 Duo

The double system lifting platform with outstanding performance data

The workshop lift in premium version for all standards. The triple air bag lifts up with 3 to lifting force as well SUV's and big limousines. Healthy posture and better visibility improve quality thanks to the extended lifting height.

Innovative extras like the extended radius for lifting points of the swivel arms and the easy fixation of the supports facilitate the handling. Due to its fold down driving tracks and ramps which is level with the rest of the lift, working is easier.

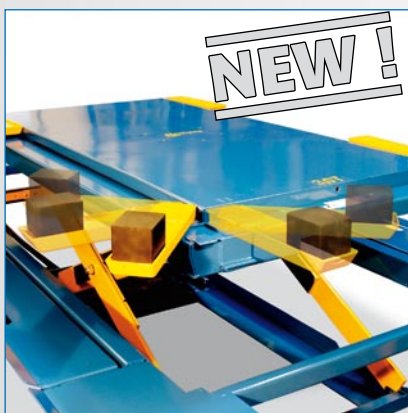

The options expands with the dual positioning of the swivel arms for lifting points.



on-ground
Installation height only 160 mm
working height: ~ 1600 mm

Item No.: HLS1600-Duo-11

Loading capacity	3.0 to
Length of the platform	3940 mm
Width of the platform	2040 mm
Weight	1050 kg
Air supply	8 bar

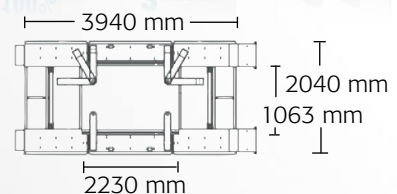

Herkules HLQ

Drive-over lift with trolleys for side transportation

For spraybooths equipped with trolleys for side transportation. Safe vehicle lifting on its wheels.

Work under better visual conditions without fatigue. While lifted, even the lower parts of the car can be reached comfortably with the spray gun. This increases the work efficiency and improves the quality.



The flush-mounted installation into the grid with adjustment of the rails.
Working height ~ 800 mm

Item No.: HLQ-01



While on the trolley, the vehicle is lifted on its wheels.
When the lift is lowered the trolleys are guided into the rails.



The vehicle can easily be pushed sideways into the drying chamber.
The lift can be used for the next vehicle.



Optimal use of existing space by sideways transportation in the body shop.

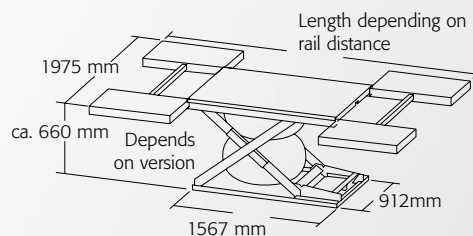

Loading capacity	2.5 to
Weight	500 kg
Air supply	8 bar

HLS 1600-U

The immersible lift for a comfortable work on the top of the car

The HLS 1600-U allows the lowering of the car in the booth ground for easy work in the roof area.

This increases the productivity and the safety of the lift.

- Regular lifting for an ergonomic work at the vehicle
- Comfortable work on the top of the vehicle thanks to the immersion of the lift into the gratings of the booth or into the body shop without ladders or other insecure tools
- Smooth lifting and lowering to desired working height
- Perfect for SUVs (sport utility vehicle) and Vans

Item No.: HLS1600-15

Loading capacity	3.0	to
Length of the platform	4030	mm
Width of the platform	1985	mm
Recessed depth	300	mm
Depth of the pit	475	mm
Weight	920	kg
Air supply	8	bar



Optimal approach to the vehicle and to the top of the vehicle.

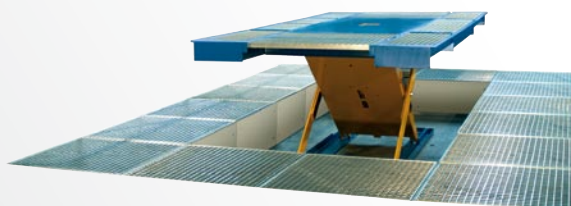

The HLS1600-U lifted for the work on the lower part of the vehicle.

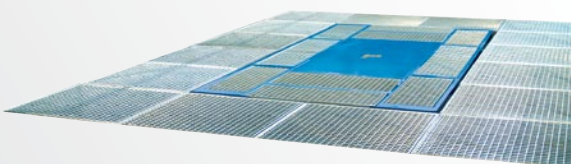

The HLS1600-U on the bottom for an easy access.

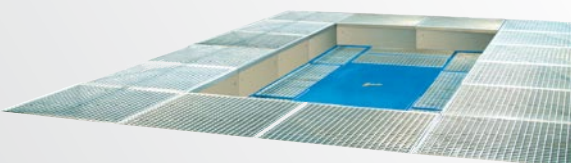

The HLS1600-U immersed for the work on the upper parts of the vehicle.

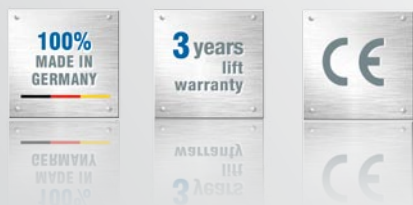

Painter

The working lift for the painter

The new development for the state-of-the-art paint shop.

Safe lifting for all works around the car.

- For prep area and spray booth
- Smooth lifting and lowering
- Easy to move
- Low space requirements
- More security for your employees

Painter 01

Working height up to 3.25 m
Platform dimensions 2000 x 700 mm
Loading capacity 150 kg
Item No.: Painter-01

Painter 02

Working height up to 4 m
Platform dimensions 3500 x 700 mm
Loading capacity 150 kg
Item No.: Painter-02

Painter 04

Working height up to 4 m
Platform dimensions 2000 x 700 mm
Loading capacity 150 kg
Item No.: Painter-04

Painter 05

Working height up to 4 m
Platform dimensions 3500 x 700 mm
Loading capacity 250 kg
Item No.: Painter-05



Air supply 8 bar

Painter



Painter secures safe standing and ergonomic working position for painter when working at higher vehicles.



On the platform are several air supplies as well as storage space for the tools. Therefore they are always within reach.

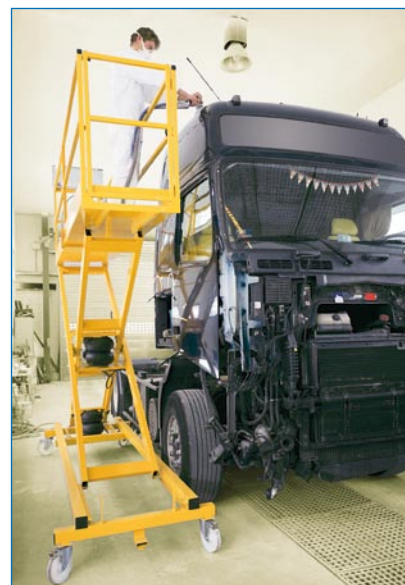

The painter is easily moveable with the wheels. Both at prep work and spray booths – excellent for small spaces.



The smooth lifting is operated directly from the lift. With suspension and storage space for tools and working materials.



Transmobile

Railfree handling and transportation system

The revolutionary system for modern paintshops. Thanks to a quicker and safer work routine, the Transmobile creates new working capacity.

The Transmobile drastically reduces the work involved in vehicle transportation. Which means more time for productive work.

- Reduces vehicle transportation times
- Can easily and safely be controlled by only one person
- Makes the most of your space capacity thanks to its tight entry angle
- Powerful self-drive with no harmful exhaust gases
- Covered vehicle surfaces remain undamaged
- Final cleaning of vehicle interior is no longer necessary
- A lift makes your work easier and increases the work quality



Transmobile

Transmobile with remote controle

Item No.: HLT-02F



The transportation system consists of the remote controlled automotive transmobile, and the HLS lifts. Can be used in any shop with a level surface - even in the spraybooth with grid floor. The use of the Transmobile pays off: better workshop utilisation, lower wage costs and a great amount of time saved.



Transmobile: The film
 Now take a simply look in the Internet!
www.herkules.de

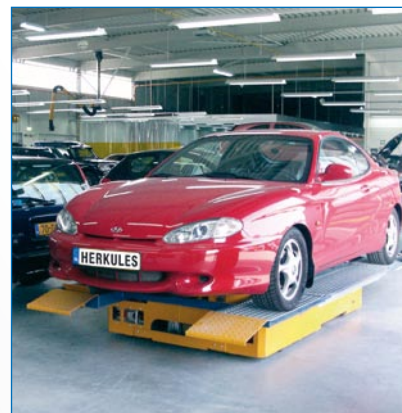
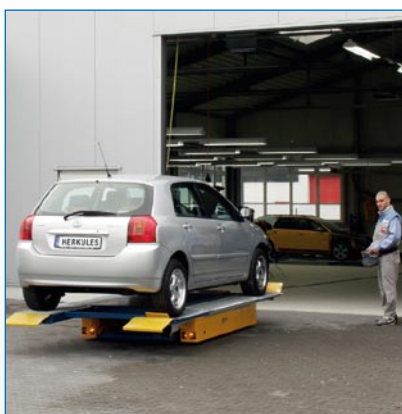
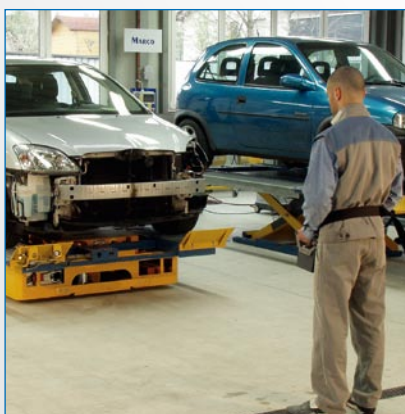

The cars are on lifts from the moment the work is started right through to the final inspections and can safely and quickly be moved to subsequent workstations.

Can be used in any shop with a level surface - even in the spraybooth with grid floor.

Moving the vehicles through tight spaces is easy and safe.



Herkules-lift mobile

The new lift for bodyshops

A fast mobile lift for service jobs with interchangeable lifting devices.



Herkules-lift mobile

The lift is ready for immediate use - no installation necessary! With an additional set of wheels it is mobile in the shop.

2.8 to capacity

- Fast lifting
- Enormous lifting height
- Various possibilities of use
- Small space requirements
- No installation required



Working height ~ 1100 mm

Item No.: HM 1100-01



Working height ~ 1000 mm

Recessed depth 115 mm

Flush mounted version
Item No.: HM 1100-04

With wheels and pole handle (accessories) it can be moved around at any time.





The swivel arms easily reach the vehicles' original lifting points.



The sturdy, long-life air cushion technology can lift up to 2.8 to.

Loading capacity	2.8	to
Weight	430	kg
Air supply	8	bar

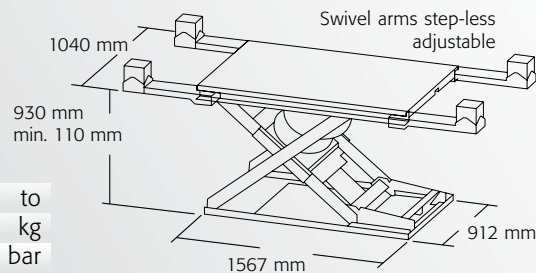

Herkules-lift RS

Fast tyre- and brake-service



Tyre service lift Herkules-lift RS

Due to the low construction height, the easy positioning of the blocks through outside markings and the high lifting speed, the lift enables you to service more vehicles in a short time. This increases the productivity of your shop, especially in the high seasons.

- 2.5 t lifting capacity
- No installation required
- Operated solely by air pressure
- Electronic wheel balance system
- Mobile with handle and wheels (optional)



Safe lifting every time thanks to the easy fixing of original lifting points. If you remove the ramp, it can also be used on small cars.

The lift has got telescoping arms, and is therefore also suitable for small vans and cars with long wheel distance.



Working height ~ 500 mm

Item No.: RS 570-01

Mobile with handle and wheels

Item No.: RS 570-02

Capacity	2.5 to
Weight	380 kg
Air supply	8 bar

Ramps step-less adjustable

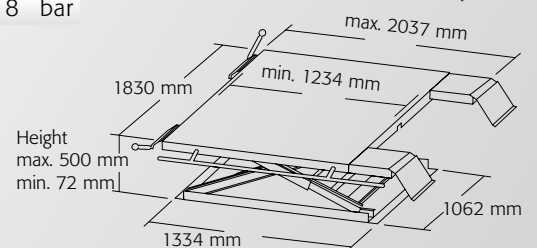

Herkules-lift K 700

Increased lifting height - more possibilities

Professional lift Herkules-lift K 700

The tyre service lift that lifts higher.
Can be used for almost all bodyshop works.
Torsion-free lifting in very little space.
With a loading **capacity of 2.8 to**
also suitable for heavy saloon cars.

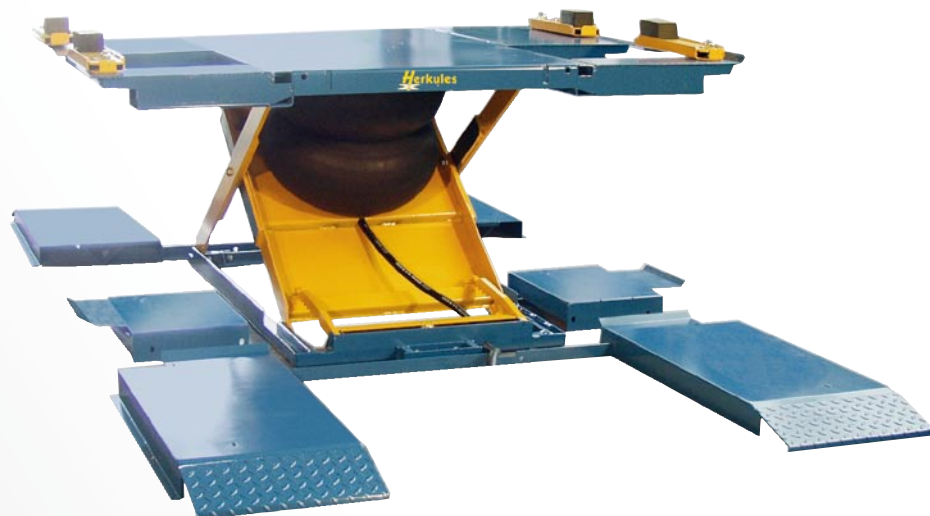

Working height ~ 1100 mm

Item No.: K700-15

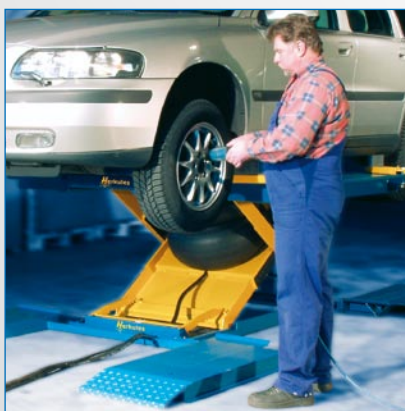

Working height approx. 1100 mm.
The pivoting bearing arms easily reach
the lifting points on the vehicle.



Easy to drive over. Ramps for drive-
through and manoeuvring positions.

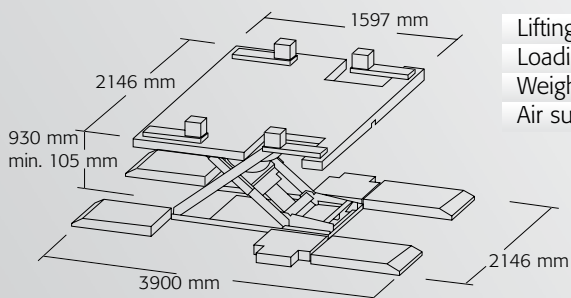

Lifting height	930	mm
Loading capacity	2.8	to
Weight	750	kg
Air supply	8	bar

Cleanpoint

The spray gun cleaning system

The new cleanpoint - a top product thanks to advanced development technology and many years of user experience.

- Fully automatic spray gun cleaning both inside and out
- More cleaning pressure in the power box
- Pneumatic automatic opening feature
- Easy to use thanks to its ergonomic design
- Clear viewing window for visual inspection
- Strong extraction for optimal exhaust
- Injection nozzle to keep the air channels of the spray gun free
- For solvents and water

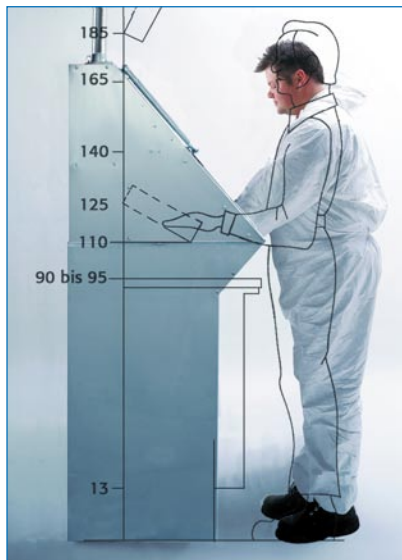

Ergonomic design according to the research results of the Federal German Institute for Labour Protection and Accident Research.



Superior cleaning performance thanks to the new **power box**.



Trolley
All the 60 litre canisters commercially available can be handled easily using this trolley with steering rollers.

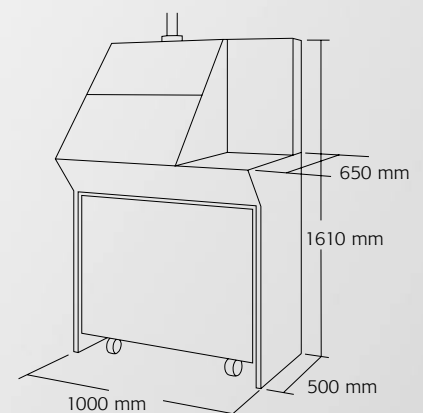

Subject to technical changes.



Cleanpoint drain station in use



Installation example of cleanpoint.



Automatic

The cleaning process runs automatically according to the pre-adjusted time and cleaning solvent volume.
For solvents
Item No.: CP-AUTO



Manual

An ergonomically designed cleaning station for manual cleaning. Can be used with both fresh and recirculated cleaning solvent.
For solvents
Item No.: CP-MANU



Automatic Multifunctional

All the components required for the different cleaning tasks in one single unit.
For solvents
Item No.: CP-MULTI



Combination Automatic Manual

The complete solution with a fully automatic spray gun cleaning system and manual cleaning unit.
For solvents
Item No.: CP-KOMBI



Waterbased cleaner CP-Aqua

Cleaning station for the manual cleaning of waterbased material guns with built-in water treatment (coagulation) possibility.
Item No.: CP-AQUA

Sono-Floc coagulation liquid

100ml container
Item No.: 840-600

Duplo / Duplo-Aqua

The compact double cleaning station for both automatic and manual cleaning

For solvents:

The Duplo is a solvent cleaning station. Next to the fully automatic power box there is also a chamber for manual brush cleaning.

Rinse fluids included.

Item No.: CP-Duplo



The manual cleaning unit has a flap to prevent solvent evaporation.



For water and solvents:

The Duplo-Aqua combines the fully automatic spray gun cleaning power box for solvents with the cleaning chamber for manual water cleaning.

The used coagulation fluids are collected in a separate bucket.

Item No.: CP-Duplo-Aqua



- Compact combination with both automatic and manual cleaning
- Made of stainless steel
- More cleaning pressure in the power box
- Easy to operate due to its ergonomic construction
- Only 1200 mm wide
- For solvents and water



The power box is covered by a transparent piece of glass which enables visual inspection.

- Easily check the dirt-level of the cleaning solvent
- Easily check the nozzles function
- Easily check the rinse fluid reserves

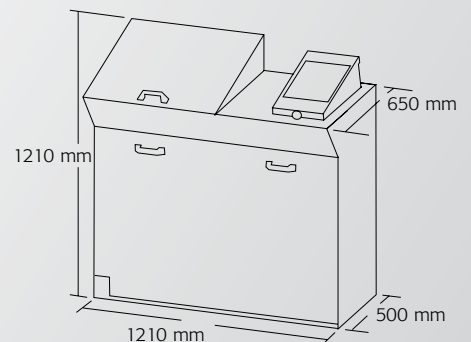

Subject to technical changes.

Herkules Aqua-Rinse

The clean station for the quick colour change of water borne paint

The clean station is special designed for the for disposable cup systems. The proper cleaning for spray guns is the result of spray out, rinsing and drying. All functions are integrated in a compact solution.

Leaving the spray booth to clean the spray gun is time consuming and inconvenient.

Proper cleaning means better quality after each quickly change.



Equipment features:

- Paint spray out funnel
- Paint channel rinse nozzle activates pump when pressed
- Air cap brush
- Air gun for drying the spray gun
- Diaphragm pump
- Clean water container

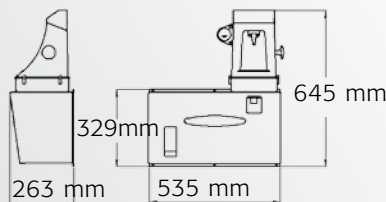

Item No.: DH-QR-10



Spray out the remaining paint



Rinse the paint channel



Wipe the air cap



Dry the gun

Hexadust

The modular designed dust extraction system

The Hexagon energy head provides work places with vacuum power, air pressure and electricity. The standard automatic start and shut off enables healthy working, a clean workshop and energy savings.

Herkules Hexadust dust extraction system

Individual vacuum dust extraction solutions for workshops of any size. A workshop analysis together with a modular system makes it possible to install the best new system or to modify an existing installation.



T 2 - Turbo / T 3 - Turbo
Up to 2 sanders at the same time.

Item No.: E1D
Item No.: E3D



T 4 - Turbo
Up to 4 sanders at the same time.

Item No.: E1C



T 6 - Turbo
Up to 8 sanders at the same time.

Item No.: E3K



The Hexagon energy head is compatible with all sanding tools.

Single- or multiple user system?

We've got them both and would be happy to consult you in your choice.

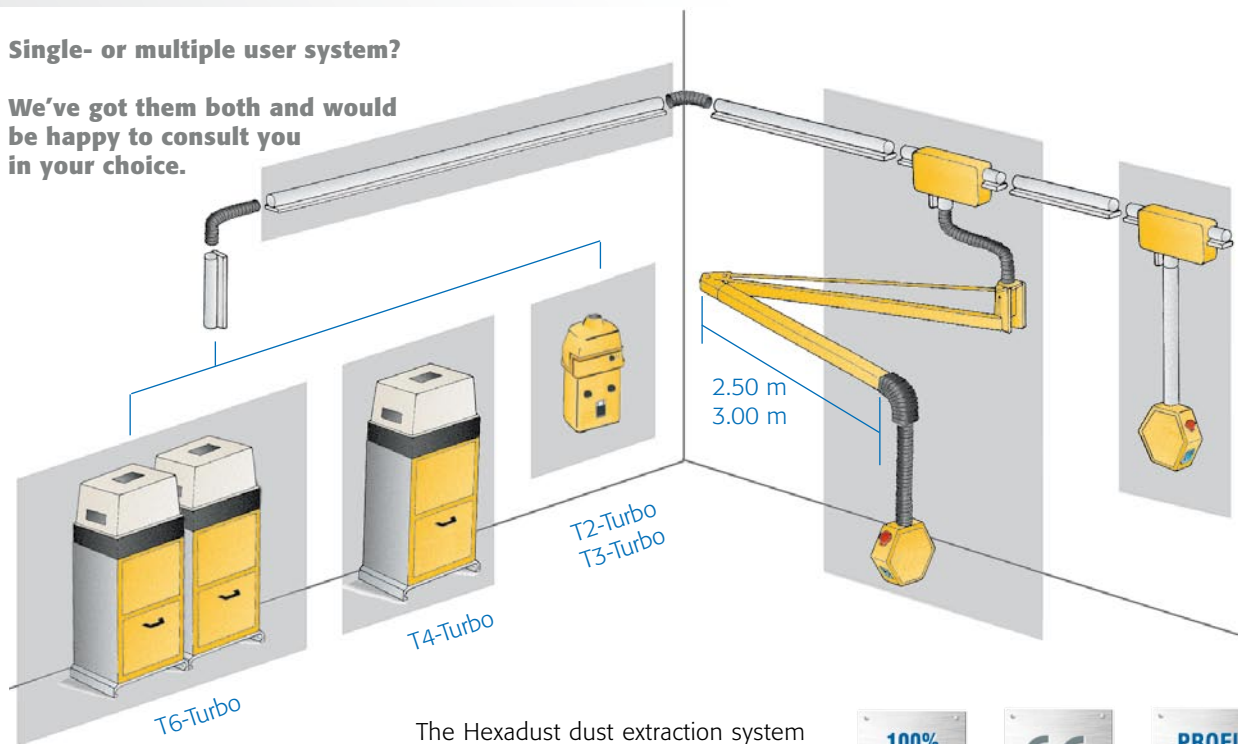

The Hexadust dust extraction system is equipped with the same type of Hexagon at any working place. The swivel arms are 5 or 6 meters long. The various ports are connected through a pipe system for vacuum, compressed air, electricity cable, incl. flexible bends and supports.



Automatic system start for both air and electrical tools as well as an automatic pneumatic filter cleaning are standard equipment.

Hexacomb Turbo

A vacuum system for multiple users for self-installation

The real multiple user system for the paint shop. A new efficiency standard for vacuum systems that are designed for self-installation.



Vacuum system Hexacomb Turbo

- Turbine unit 1.5 kW / 230 V
- Swivel arm 5 m
- Hexagon energy head
- Holders for hoses and tools

Item No.: HEXA-COMB-T2A

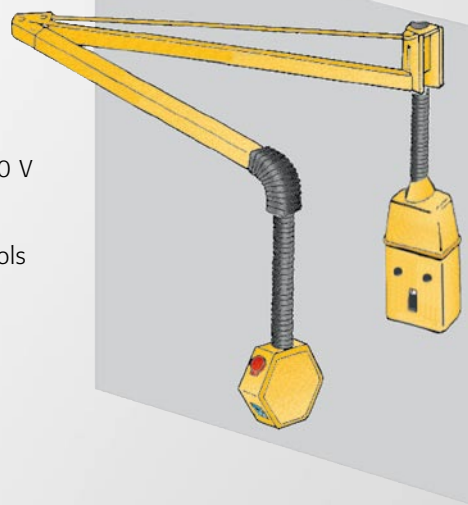



The swivel arms reach to several working places in the preparation area.

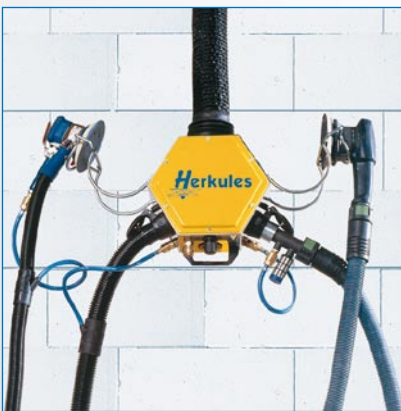

Compatible with all sanding tools, for example Festo, Hutchins and Rupes.

Tool holder at the Hexagon.



Automatic on / off switching for air- and electrical operated tools.

Long-lasting, super strong vacuum power, super silent turbine and a dustbin with level indicator; easy dump without changing the dust-bag.



The turbo power!

The side-channel blowers with a new strength. The turbine has a designed lifetime of approx. 25.000 hours - compared to 800 hours of traditional turbines. Branded quality with a 2-year-warranty.

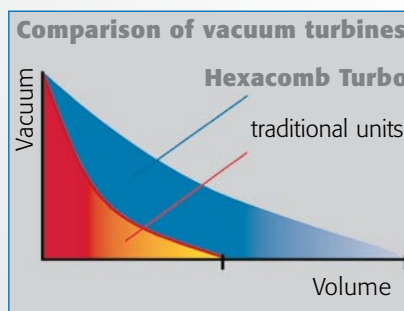

Single- or multiple user system?

We've got them both and would be happy to consult you in your choice.

T-2 Mobile

The mobile working place in the prep area

All the necessary tools and materials you need at your hand.

Herkules T-2 Mobile

- Lockable tool case
- Rubber layer working and storage place

Integrated strong vacuum turbine:

- Strong vacuuming power: 1.5 kW / 230 V
- Long lifetime (25.000 hours of operation)
- 2-year-warranty on the turbine
- Automatic on / off for electronic and air-operated machines
- Automatic filter cleaning
- Low running turbine
- Dustbin that can be emptied easily
- Compatible for all traditional sanding tools like Hutchins, Rupes, Festo, SIA, etc.

Item No.: T2M



- Standard:
- Holders for accessories and sanding materials
 - Hose holder

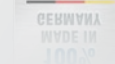

Hoses

no swivel-joint

360° swivel-joint



Available hoses

Vacuum hose

- F1A** 5 m
- F1B** 7 m
- F1C** 9 m

Vacuum and compressed air

- F1D** 5 m
- F1E** 7 m
- F1F** 9 m

- F3D** 5 m
- F3E** 7 m
- F3F** 9 m

Vacuum with compressed air and grounding

- F1D-E** 5 m
- F1E-E** 7 m
- F1F-E** 9 m

Vacuum and electricity

- F2D** 5 m
- F2E** 7 m
- F2F** 9 m

Accessories

Adaptor for FESTO-machines
(only for FESTO IAS 2 necessary)
between turbine and hose
or between hose and Hexagon

Item No.: 340-007

Lucky Table

The preparation table for the paintshop

Herkules Lucky table

The table is made of **stainless steel** and has a lot of storage space for painting materials and tools. Everything is at your hand, saving both time and effort.

The **lowered working surface** prevents solvent overflow. It has also got an **outflow tunnel** for pouring into a collecting tank. A **paper roll holder** is available as an accessory.

Optimum solvent extraction:

Thanks to the defined extraction at the bottom of the working surface, reliable extraction is possible. The solvent particles concentrated at the bottom are optimally drawn off through strong suction.

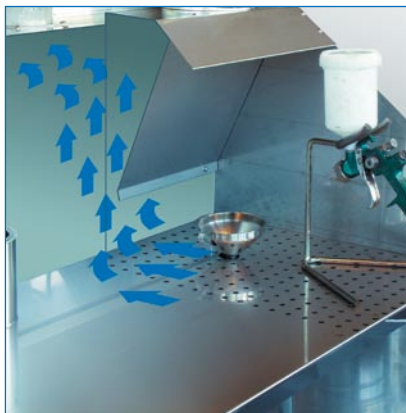

The extraction system can be connected to an already existing system. Herkules has a pneumatic extraction system available as an accessory.

Width 1200 mm Item No.: LT-05

Width 1800 mm Item No.: LT-06

Overall height 1395 mm

Depth 650 mm

Paper roll holder and extraction system available as accessories.



Paint stand



Herkules paint stand

The quick and safe painting and assembly stand for paint- and body-shops.

- Has a wide range of adjustments
- Robust but easy to handle
- Extendable

Item No.: BL-01

Drain station

The Herkules **drain station** is the cost-saving add-on unit for automatic spray gun cleaning systems. Drained guns and cups go easy on the cleaning agent in the system. The increased service life saves a lot of money.

- Thanks to the increased service life it saves solvents
- With blow-out channel for cleaning the gun interior
- Suitable for conventional and waterbased materials
- Clean workstation
- Optional extraction system available as an accessory

Item No.: CP-TG01

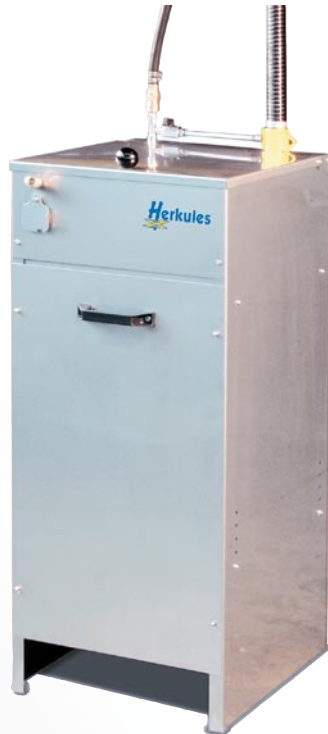

The residual paint is collected in a canister. To prevent odour and health damage, an extraction system is available as an accessory.



Spray guns and paint cups are simply placed in the drip openings.

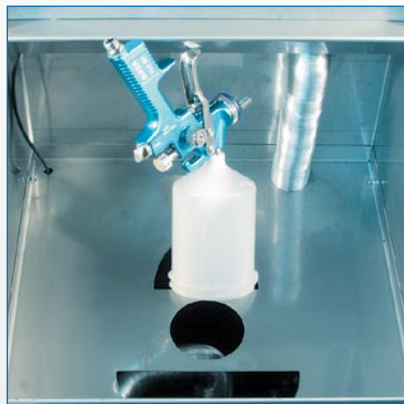

If you use a little solvent, the residual paint can be blown into an outlet piping.

Height	1020	mm
Width	400	mm
Depth	500	mm



The **drain station** is the ideal add-on unit for all automatic spray gun cleaning systems. It drastically increases the service life of cleaning agents in the systems.

Paper baler

Provides space and reduces waste disposal charges

Paper baler

Up to 5 to pressing capacity reduces volume drastically. Whether packing or masking - paper from the paintshop - the big front flap swallows it all!
Tied up easily in pressed state.

Achieves a 20 times more effective use of waste containers, and drastically reduces the waste disposal charges.

Can be equipped with a set of wheels for flexible positioning on request.

Flap opening: 415 x 680 mm
Bundle weight: 25 - 50 kg

Item No.: PAP-01

Carriage Item No.: 300-045

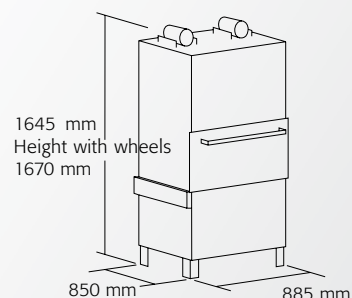

Capacity	5.0 to
Weight	250 kg
Air supply	8 bar



Aluminium step-bench

For painting large vehicles

An essential "helping hand" when painting the roofs of larger vehicles such as Vans and Pick-Ups. When it is not in use you can easily put it away - it does not require a lot of space.

Item No.: 300-257

Loading capacity	120 kg
Weight	5.0 / 6.5 kg
Dimensions	1000 x 330 x 325 mm
	1190 x 330 x 600 mm



Your contact persons at Herkules:



Karsten Grötecke
Export Manager
Phone +49 5 61/5 89 07 68
Mobile +49 1 72/5 74 48 57
groetecke@herkules-lift.de



René Bartsch
Managing Director
Phone +49 5 61/5 89 07 30
bartsch@herkules-lift.de



Kirsten Clemen
Customer Service
Phone +49 5 61/5 89 07 26
clemen@herkules-lift.de



Andrea Kuntke
Secretary
Phone +49 5 61/5 89 07 29
kuntke@herkules-lift.de



Maria Kruse
Customer Service
Phone +49 5 61/5 89 07 26
kruse@herkules-lift.de



Jörg Andres
Customer Service
Phone +49 5 61/5 89 07 33
andres@herkules-lift.de

V 10

Subject to technical changes.



Headquarters & Production :
Herkules Hebetchnik GmbH
Falderbaumstr. 34
D-34123 Kassel
Founded: 1974

Member of the Hedson Group

Phone: +49 561 / 5 89 07-0 · Fax: +49 561 / 5 89 07-45 · e-mail: info@herkules-lift.de · Internet: www.herkules.de